

LUX-B-ID

● Compact ● 50 N to 20 kN

Compact Tension/Compression Load Cell



Note: For transducers providing both positive and negative output values an average of both values are written as the rated output.

Suitable for Measuring and Controlling Loads Applied to Small-scale Presses and Press-fitting Devices

- High sensitivity
- Waterproof connector
- Stainless steel
- Easy installation

Compact & lightweight design with a screw-shape load receiving portion facilitates easy installation to equipment. Furthermore, the cable is connected using a connector, therefore there are no wiring problems, and cable replacement is easy. Work is also possible if the cable is replaced with one resistant to repeated bending (Flexible cable). Please attach a suffix of M1Z3K to the model name.

Specifications

Performance

Rated Capacity	See table below.
Nonlinearity	Within $\pm 0.15\%$ RO for 50 N to 2 kN Within $\pm 0.1\%$ RO for 5 to 20 kN
Hysteresis	Within $\pm 0.15\%$ RO for 50 N to 2 kN Within $\pm 0.1\%$ RO for 5 to 20 kN
Repeatability	0.05% RO or less
Rated Output	± 0.85 mV/V or more for 50 N ± 0.9 mV/V or more for 100 N to 1 kN ± 1.3 mV/V or more for 2 to 20 kN

Environmental Characteristics

Safe Temperature	-20 to 80°C
Compensated Temperature	-10 to 70°C
Temperature Effect on Zero	Within $\pm 0.03\%$ RO/°C for 50 to 200 N Within $\pm 0.005\%$ RO/°C for 500 N to 20 kN
Temperature Effect on Output	Within $\pm 0.005\%$ /°C

Electrical Characteristics

Safe Excitation	10 V AC or DC for 50 to 200 N 15 V AC or DC for 500 N to 20 kN
Recommended Excitation	1 to 5 V AC or DC for 50 to 200 N 1 to 10 V AC or DC for 500 N to 20 kN
Input Resistance	375 $\Omega \pm 1.5\%$
Output Resistance	350 $\Omega \pm 1\%$
Dedicated connection cable	TE-45
Cable	6-conductor (0.08 mm ²) chloroprene shielded cable, 4.4 mm diameter by 3 m long, with connector plug to the case side, and bared to amplifier side (Shield wire is not connected to the case.)

Mechanical Properties

Safe Overloads	150%
Natural Frequencies	See table below.
Materials	SUS (Metallic finish)
Weight	Approx. 260 g (5 to 20 kN) Approx. 90 g (500 N to 2 kN) Approx. 50 g (200 N or less), (Excluding cable)
Degree of Protection	IP67 (IEC 60529)

Models	Rated Capacity	Natural Frequencies	*Recommended Tightening Torque (N.m)
LUX-B-50N-ID	± 50 N	≈ 8 kHz	3 N.m
LUX-B-100N-ID	± 100 N	≈ 11 kHz	
LUX-B-200N-ID	± 200 N	≈ 14 kHz	
LUX-B-500N-ID	± 500 N	≈ 16 kHz	10 N.m
LUX-B-1KN-ID	± 1 kN	≈ 21 kHz	
LUX-B-2KN-ID	± 2 kN	≈ 27 kHz	80 N.m
LUX-B-5KN-ID	± 5 kN	≈ 18 kHz	
LUX-B-10KN-ID	± 10 kN	≈ 21 kHz	
LUX-B-20KN-ID	± 20 kN	≈ 25 kHz	

Optional Accessories

- Mount base CX (Page 2-20)
- Ball joint TU (Page 2-74)
- Whirl-stop coupling TSC (Page 2-49)
- Whirl-stop brackets TS (Page 2-49)

Bared at the tip
(For TEDS installation)



To Ensure Safe Usage

If impact is expected in receiving tensile loads, select a load cell with the rated capacity higher by one rank than the operating load.

● Physical quantity indication

● Static measurement ● Dynamic measurement

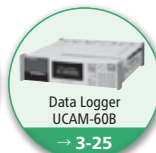

■ Dimensions

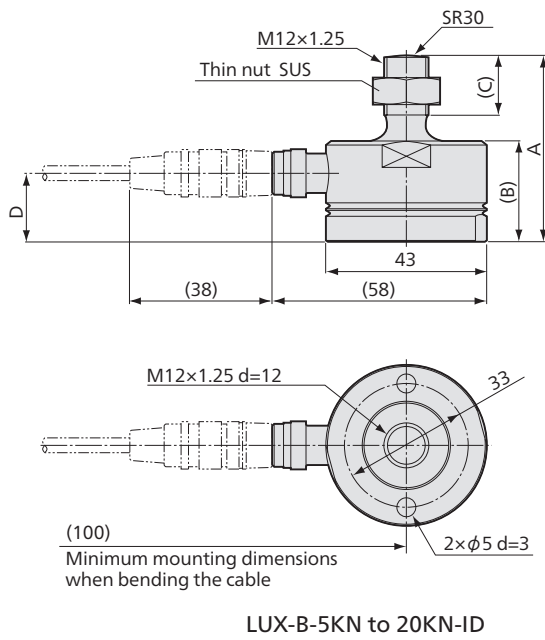
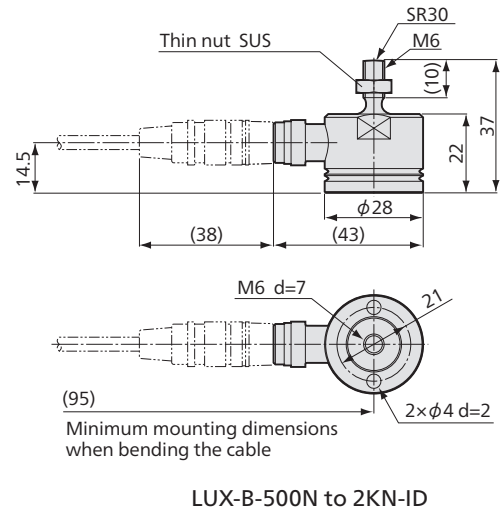
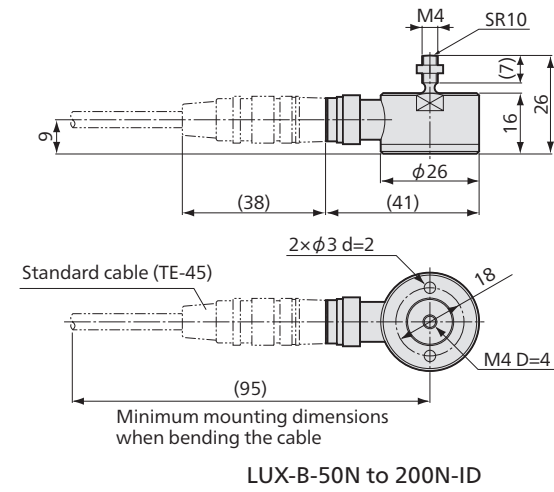

Models	A	B	C	D
LUX-B-5KN-ID	49	26.5	15	19.5
LUX-B-10KN-ID	51	27.5	16	18
LUX-B-20KN-ID	53	27	16	18

■ Dimensions of Mount Base

● Mount Base CX

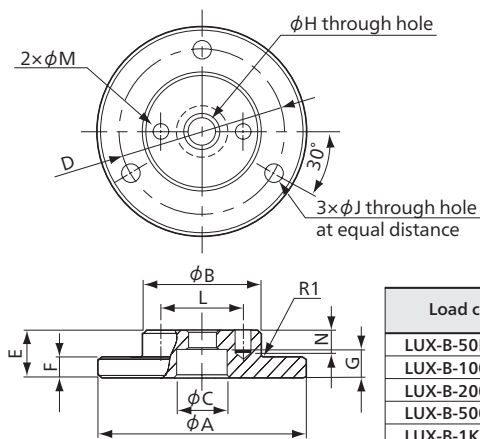

Load cells	Mount Bases	φA	φB	φC	D	E	F	G	φH	φJ	L	φM	N	Weight
LUX-B-50N-ID	CX-2	43	26	9	35	7	2.5	4.5	4.5	5	18±0.1	3 ^{0.20} _{0.06}	4.5	≈ 40 g
LUX-B-100N-ID														
LUX-B-200N-ID														
LUX-B-500N-ID	CX-4	48	29	13	39	12	5	7	7	5	21±0.1	4 ^{0.2} _{0.1}	6	≈ 100 g
LUX-B-1KN-ID														
LUX-B-2KN-ID														
LUX-B-5KN-ID	CX-6	68	44	20	57	20	10	13	13	7	33±0.1	5 ^{0.2} _{0.1}	6	≈ 350 g
LUX-B-10KN-ID														
LUX-B-20KN-ID														

Hexagon socket head bolts for connection among load cells, mount bases, and locking pins are attached to the mount base.



■ Dimensions in Combination with Special Accessories

● In Combination with Mount Base CX

The patch should be prepared by user or CA-2F or the equivalent should be used.
This combination does not apply to tensile load measurement.

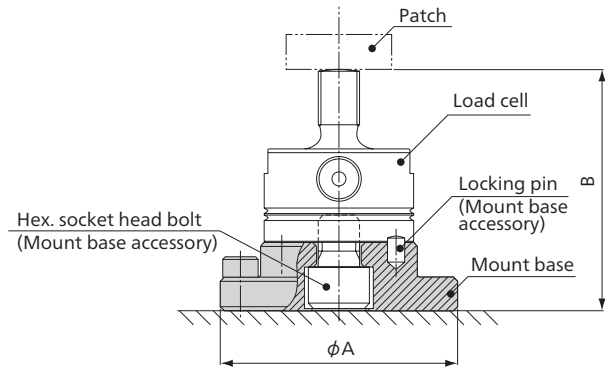

Load Cells	Mount Bases	(A)	(B)
LUX-B-50N-ID	CX-2	43	33
LUX-B-100N-ID			
LUX-B-200N-ID			
LUX-B-500N-ID	CX-4	48	49
LUX-B-1KN-ID			
LUX-B-2KN-ID	CX-6	68	69
LUX-B-5KN-ID			71
LUX-B-10KN-ID			73
LUX-B-20KN-ID			

● In Combination with Ball Joint TU, Whirl-stop Coupling TSC and Whirl-stop Bracket TS

This combination does not apply to compressive load measurement.

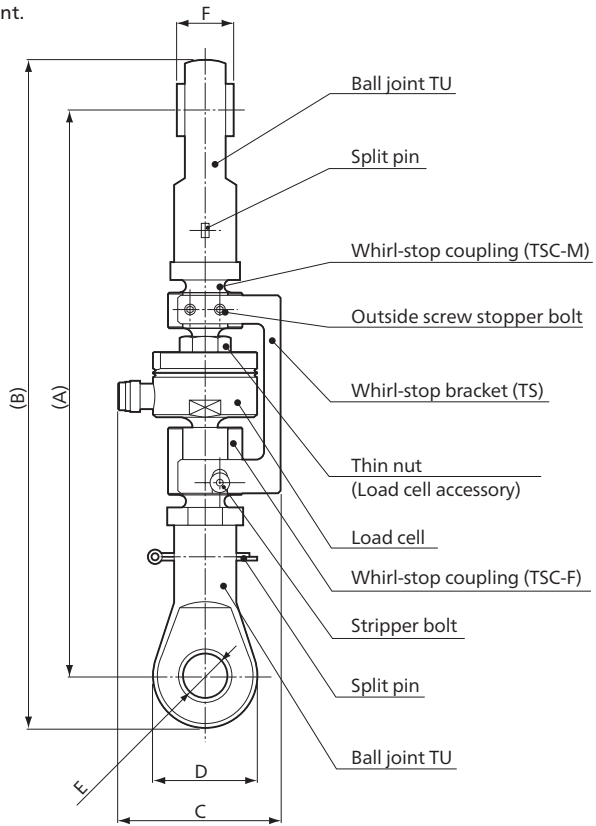

*Note that the Whirl-stop Bracket TS is not a safety device to be used when a load exceeding the safe overload is applied. If exceeding safe overload is applied, install a safety device on customer side before use.

Load Cells	Whirl-stop Couplings	Whirl-stop Brackets	Ball Joints	(A)	(B)	C	D	E	F
LUX-B-50N-ID	TSC-2M TSC-2F	TS-2	TU-6B	102	120	44.7	18	6	9
LUX-B-100N-ID									
LUX-B-200N-ID									
LUX-B-500N-ID	TSC-4MB TSC-4FB	TS-4B	TU-12B	165	195	50.5	30	12	16
LUX-B-1KN-ID									
LUX-B-2KN-ID	TSC-6MB TSC-6FB	TS-6B	TU-18B	237	279	67	42	18	23
LUX-B-5KN-ID				239	281				
LUX-B-10KN-ID				241	283				
LUX-B-20KN-ID									

To Ensure Safe Usage

Check the strength of the material to which the load cell is tightened.

Pay attention to strength of fastened parts which is screwed into the LUX-B. When using the LUX-B with rated capacity more than 2 kN or more, use the fastened parts made of a material with tension strength more than 800 N/mm²

Typical recommended material: SUS630 (H900) HRC40 to 47
SCM435 HRC30 to 38

*For tensile load measurement, take care never to exceed the safe overload rating.



LUX-B Safe Bending Moments

● Figures below show the safe bending moments against lateral loads with a load applied in sensitivity direction (Vertical direction)

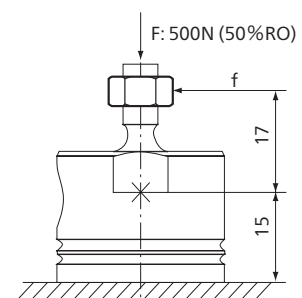
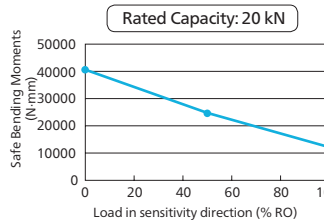
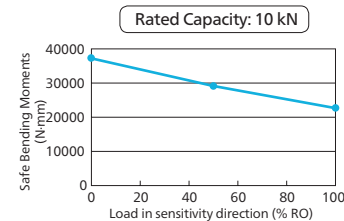
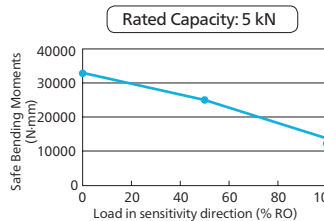
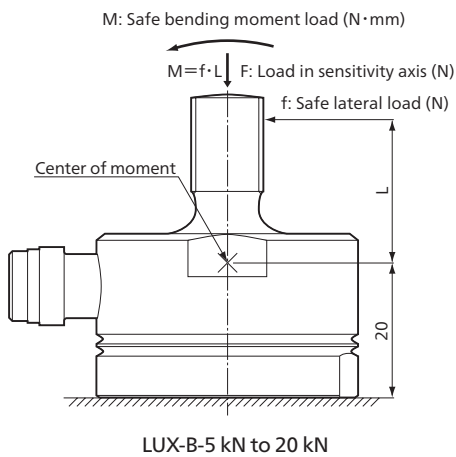
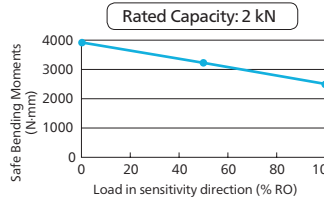
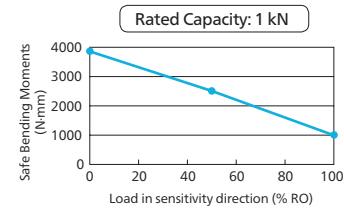
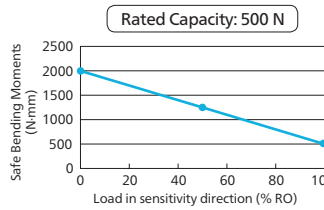
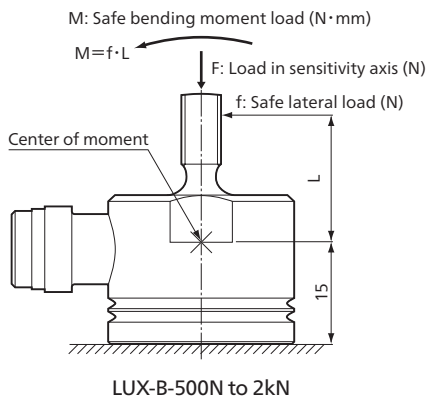
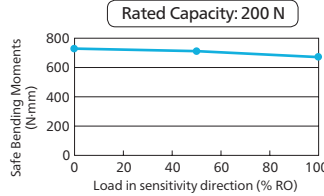
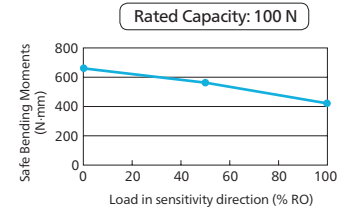
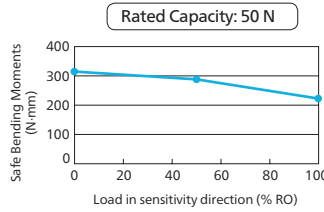
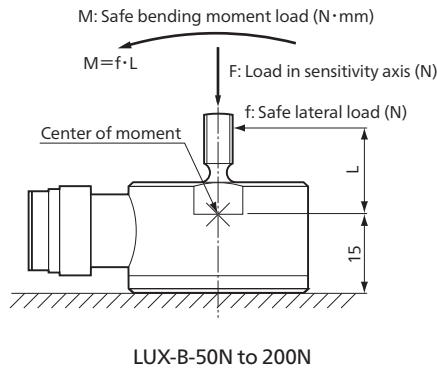

Fig. 1

How to Obtain Safe Lateral Loads

Shown here is an example calculating the safe lateral load when the LUX-B-1kN receives a load in sensitivity direction (Vertical direction). (See Fig. 1.)

The safe lateral load f (N) which is applied to the screw at the distance of 17 mm from the center of the moment when a load of 500 N (50% the rated capacity) is applied in sensitivity direction and is obtained as follows:

According to Graph-1, safe bending moment, M , is approximately 2500 N·m when a load of 50% the rated capacity is applied in sensitivity direction. Since the relation between safe lateral load f , and safe bending moment M is $M = f \cdot L$,

$$f = \frac{M}{L} = \frac{2500}{17} = 147.1 \text{ N}$$

Therefore, the safe lateral load f is 147.1 N.

