

AS-TG

- 9.807 to 196.1 m/s²
- Simultaneous Measurement of Acceleration in X, Y and Z Directions

Small-sized Triaxial Acceleration Transducer



Specifications

Performance	
Rated Capacity	See table below.
Nonlinearity	Within ±1% RO
Hysteresis	Within ±1% RO
Rated Output	0.5 mV/V or more
Environmental Characteristics	
Safe Temperature	-10 to 60°C
Electrical Characteristics	
Safe Excitation	6 V AC or DC
Recommended Excitation	1 to 3 V AC or DC
Input Resistance	121 Ω±1.7%
Output Resistance	121 Ω±1.7%
Cable	4-conductor (0.08 mm ²) vinyl shielded cable, 3.2 mm diameter by 5 m long, terminated with connector plug PRC03-12A10-7M (Shield wire is not connected to the case.)
Mechanical Properties	
Safe Overloads	1000% (With a stopper)
Frequency Response	See table below.
Transverse Sensitivity	4% RO or less
Weight	Approx. 110 g (Excluding cable)

Able to Withstand against 10 Times Larger Overload than Rated Capacity by the Built-in Overload Stopper

AS-TG series acceleration transducers have 3 incorporated miniature acceleration transducers to measure simultaneously 3 axial accelerations (X, Y, and Z). Not only are interferences of AS-TG series among each axes little, but also AS-TG series withstand against 10 times larger overload than rated capacity.

Models	Rated Capacity (Reference Value)	Frequency Response (At 23°C)
AS-1TG	±9.807 m/s ² (±1 G)	DC to 40 Hz ±5%
AS-2TG	±19.61 m/s ² (±2 G)	DC to 60 Hz ±5%
AS-5TG	±49.03 m/s ² (±5 G)	DC to 100 Hz ±5%
AS-10TG	±98.07 m/s ² (±10 G)	DC to 150 Hz ±5%
AS-20TG	±196.1 m/s ² (±20 G)	DC to 250 Hz ±5%

Notes: Measurement range of up-down direction is narrowed by 1 G (9.807 m/s²) because gravity acceleration is always applied to acceleration transducers. In terms of AS-1TG, detected value exceeds rated capacity in positive side toward gravity direction. Although AS-TG acceleration transducers are not broken under safe overload rating, characteristics are out of warranty.

Dimensions

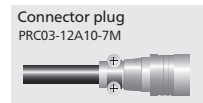
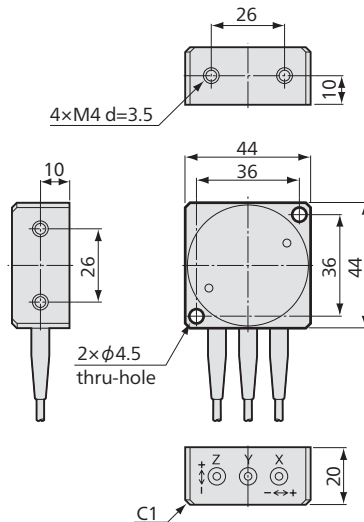

Dynamic measurement

AS-TG Recommended products for combination

- Strain Amplifier DPM-900 Series → 3-5
- Signal Conditioner CDV-900A → 3-9
- Compact Recording System EDX-10 series → 3-49
- Universal Recorder EDX-100A → 3-63