



Type 250

Lock-up Air Relay

Reliable for fail in place applications

The ControlAir Type 250 Lockup Air Relay is a reliable unit for fail in place applications of control valves when air supply drops below acceptable pressure levels. Valve or damper position is maintained by capturing air pressure inside the diaphragm chamber (or piston cylinder) of the actuator, when the supply pressure falls below the desired set value.

Features

- **Two Pressure Ranges Available**
15-60 psig (1-4 BAR) or
30-120 psig (2-8 BAR)
- **Manual Relief Valve**
Allows system bleed down
- **Corrosion-Resistant Construction**
- **Aluminum or 304 Stainless Steel Material Option**
- **Mounting Bracket Standard for Ease of Installation**
- **No Leakage in Lock-up Position**



Type 250 Lock-up Air Relay

Principles of Operation

The Type-250 Lock-up Air Relay is designed so that when the supply air pressure falls below a set value (cut-off point) the unit traps the air pressure in the diaphragm chamber of the actuator. The cut-off set point is set to a desired value by compressing the spring adjusting screw. The cut-off set point is adjustable and is generally set at a higher value than required for operation of the control valve. If the control pressure is 3-15 psig (0.2-1.0 BAR), the cut-off set point could be set at 20 psig (1.35 BAR), for example.

Ported with Flow Booster (P)

Cut-off set point value has been factory adjusted. Should it be required to re-adjust the set point, it can be made either while the unit is connected to the system or separately on the test bench. Inlet supply air and the outlet pressure gauge should be available to re-adjust.

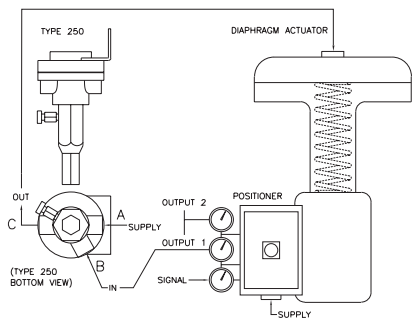

To adjust the cut-off set point, remove the cap and adjust the spring adjusting screw until desired outlet cut-off pressure is achieved. Turning the adjusting screw clock-wise will increase the cut-off setting and turning it counter-clock wise will reduce the cut-off setting. Note that the lock-up relay has a differential pressure of 2.5 psig (.17 BAR). Replace cap securely after having re-adjusted the cut-off set point.

Caution: Open the Manual Relief Valve to vent the actuator diaphragm chamber when control valve handwheel (override) is operated to avoid possible damage to the actuator diaphragm.

Specifications

Port Size (Inlet, Outlet, Supply)	1/4" NPT
Cut-off Pressure Range	15-60 psig (1-4 BAR) 30-120 psig (2-8 BAR)
Supply Pressure	125 psig (8.35 BAR) maximum
Cv Value	0.38
Temperature Limits	0° to 160°F (-18° to 71°C)
Weight	Aluminum: 2.1 lbs (0.95 kg) Stainless Steel: 4 lbs (1.8 kg)
Materials:	Housing: Aluminum or 304 Stainless Steel Diaphragm: Nitrile/Nylon Spring: Plated Steel Plug: Stainless Steel/Nitrile Trim: Stainless Steel Bracket: Plated Steel or 304 Stainless Steel

Dimensions

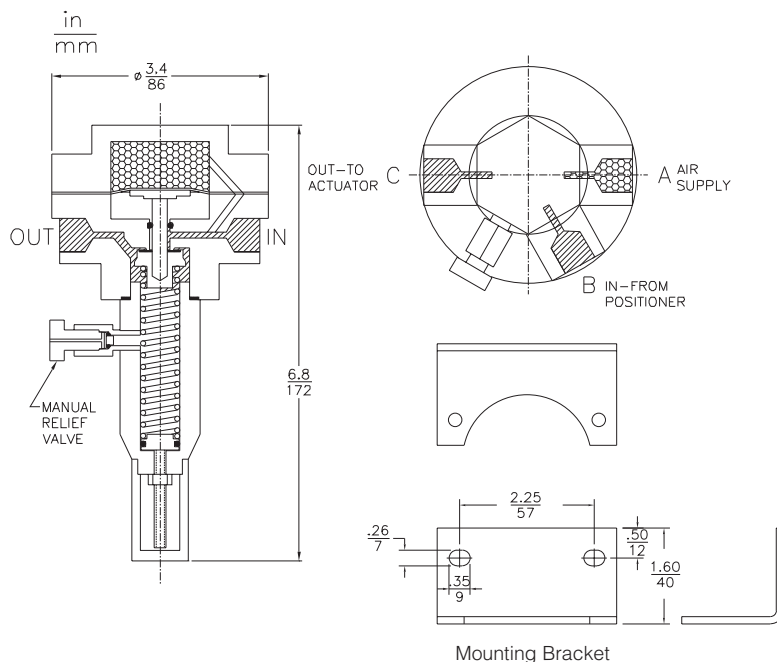

Ordering

Part Number	Port Size (NPT)	Set Point Range	Factory Set Point Range	Construction
250-AA	1/4"	15-60 psig (1-4 BAR)	20 psig (1.4 BAR)	Aluminum
250-BA	1/4"	30-120 psig (2-8 BAR)	85 psig (5.8 BAR)	Aluminum
250-AS	1/4"	15-60 psig (1-4 BAR)	20 psig (1.4 BAR)	Stainless Steel
250-BS	1/4"	30-120 psig (2-8 BAR)	85 psig (5.8 BAR)	Stainless Steel

Warranty ControlAir, Inc. products are warranted to be free from defects in materials and workmanship for a period of eighteen months from the date of sale, provided said products are used according to ControlAir, Inc. recommended usages. ControlAir, Inc.'s liability is limited to the repair, purchase price refund, or replacement in kind, at ControlAir, Inc.'s sole option, of any products proved defective. ControlAir, Inc. reserves the right to discontinue manufacture of any products or change products materials, designs or specifications without notice. Note: ControlAir does not assume responsibility for the selection, use, or maintenance of any product. Responsibility for the proper selection, use, and maintenance of any ControlAir product remains solely with the purchaser and end user. Drawing downloads available at www.controlair.com



8 Columbia Drive / Amherst, NH 03031 USA / www.controlair.com / sales@controlair.com / 603-886-9400 / FAX 603-889-1844

An ISO-9001:2008 Certified Company